

The home of the turntable

THE VINYL ENGINE®

For more turntable manuals and setup information
please visit www.vinylengine.com

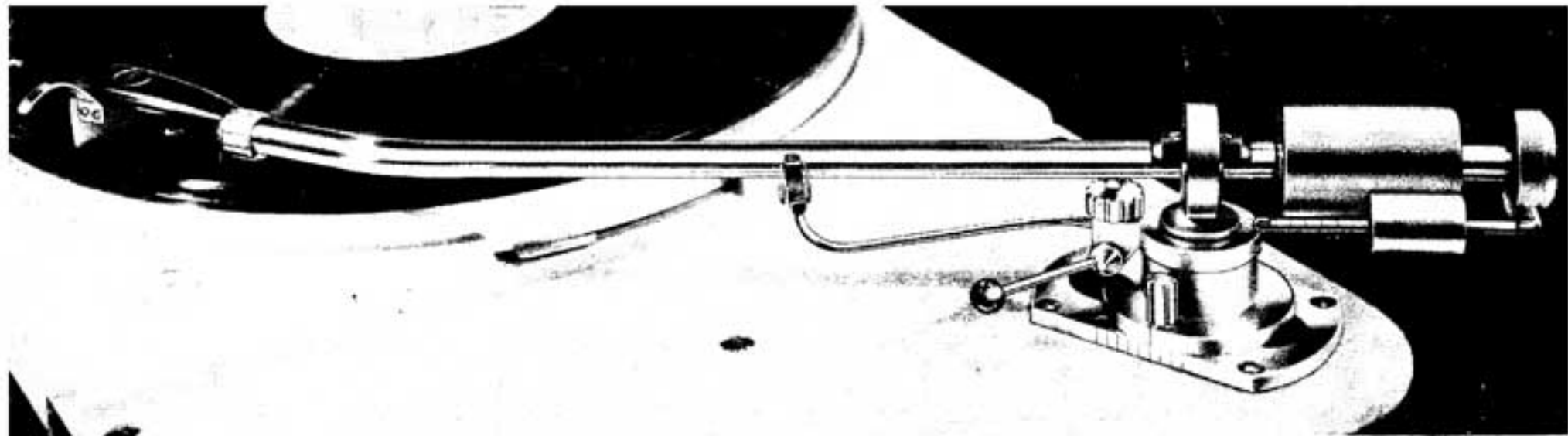

SME

MODELS 3009 & 3012

PRECISION PICK-UP ARMS

INSTRUCTIONS FOR USE

INTRODUCTION

This pick-up arm has been built to the highest engineering standards and, as a precision instrument, demands very careful handling and installation. The following instructions have been prepared to enable the user to benefit by the outstanding performance of which it is capable. Please read them through carefully **BEFORE UNPACKING THE UNIT.**

UNPACKING

- 1** Remove the mounting template and alignment protractor from the carton.
- 2** Next remove the perforated centre fitting followed by the two end fittings, which should be carefully disengaged from either end of the arm. Support the arm with one hand during this operation to avoid straining it.
- 3** Turn the carton on its side and open the bottom flaps.
- 4** Push evenly on the bottom of the cradle now exposed, so that it is kept square, and eject from the top of the carton.
- 5** Carefully remove the separately packed parts from the wrappings within the cradle and place them safely on one side.
- 6** Remove the arm from its cradle by disengaging the bed plate from the slotted card fittings on either side. Untie the tape holding the knife-edge bearings. **DO NOT REMOVE THE RUBBER BAND WHICH HOLDS THE ARM IN ITS REST UNTIL DIRECTED.**

IMPORTANT. Replace all packing pieces in the carton and save for possible re-use. The S.M.E. arm would be seriously damaged if transported in an improvised packing.

ASSEMBLY

As a precaution against damage in transit the S.M.E. arm is packed with the balance weights removed. To assemble proceed as follows:—

Release the set screw 'A' in the base with one of the hexagon keys provided (Fig. 2). Turn the base to approximate position relative to the arm rest which can be seen in Fig. 1. Relock the set screw lightly. Note that the graduation marks on the edge of the bed plate should face outwards from the turntable.

Slide the balance weight on to the tone arm extension, noting that the end remote from the radial hole goes on first and that the radial hole should be underneath and out of sight (Fig. 2). An internal spring-loaded ball holds the weight in any position. The end cap complete with way rod and rider weight is now fitted and secured by tightening the set screw 'B'. The part of the way rod which passes through the end cap should be horizontal.

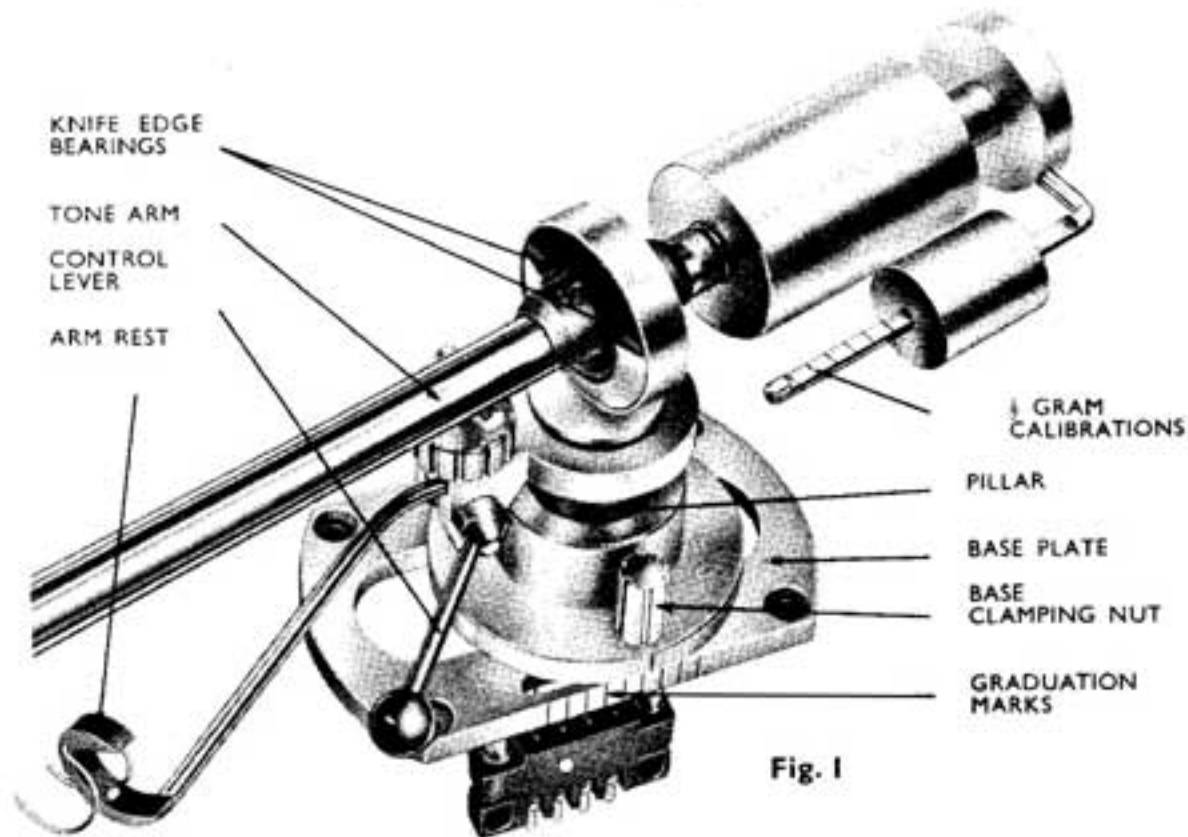

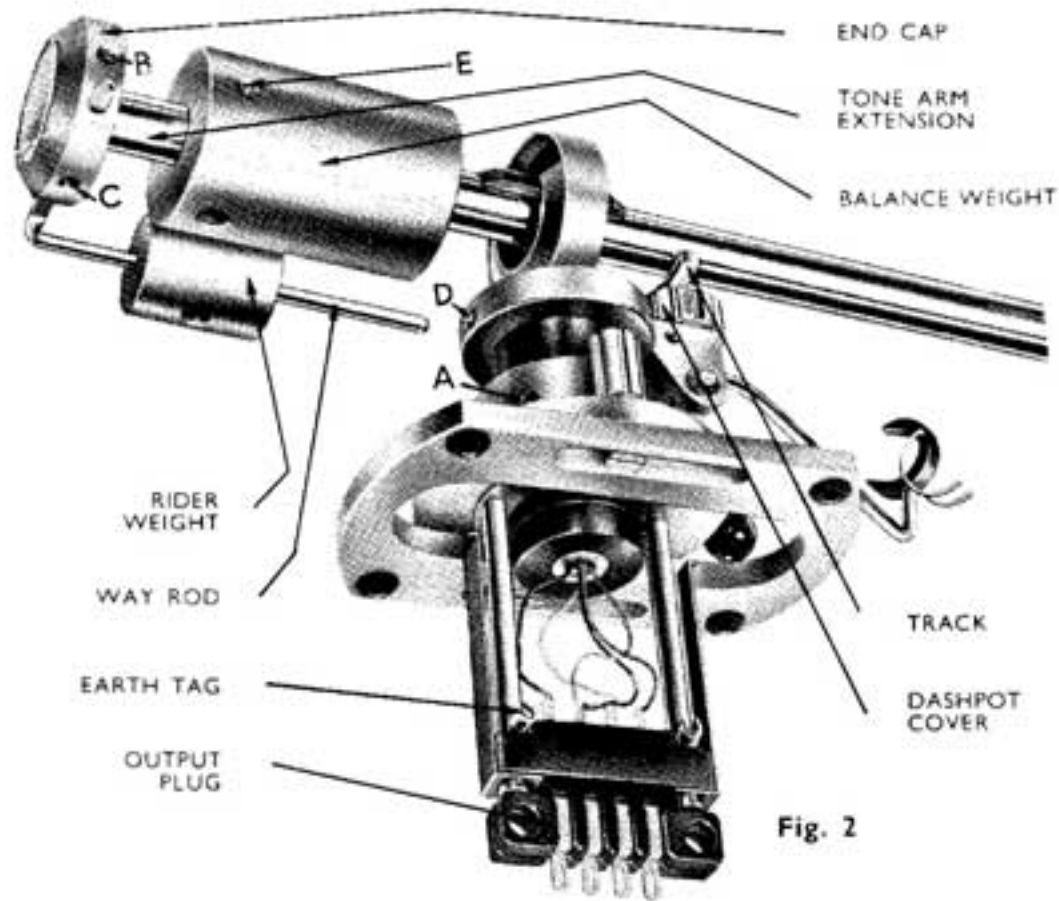

Fig. 2

MOUNTING

The mounting template has instructions printed on it. Cut the necessary slot in the motor board. If it is impracticable to position with the slot and turntable spindle on the same centre line it should be as near as possible. Bear in mind that the range of adjustment afforded by the sliding base will otherwise be reduced accordingly. Position the bed plate symmetrically over the slot. Spike through each of the four rubber grommets. Remove the unit. A spare wood screw provided is now screwed into each spiked position in turn. This screw is discarded and the unit fitted with the remaining four screws which will enter easily into the holes already made without damage to their heads. Screw down until screw shoulders touch the rubber grommets and then give each another half turn.

ARM REST ADJUSTMENT

At this stage the arm rest should be re-positioned so that it is well clear of the turntable. Release the set screw 'A' slightly and turn the rest and pillar as required, at the same time setting approximately for height in relation to the turntable. Final height adjustment must be made later after fitting the shell. Relock the set screw.

FITTING A CARTRIDGE

The S.M.E. shell is suitable for all standard phono cartridges. Screws and pillars at $\frac{1}{2}$ in. spacing permit direct mounting or use of a bracket when required.

A special adaptor is available for Decca heads.

Connections to the terminal pins in the shell are made using the tails provided—not by direct soldered connections. Damage to the shell will result if this is attempted.

CONNECTIONS

These appear as figs 3 and 4 when viewing the arm socket from the front and correspond with the same numbers at the output socket. For stereo cartridges use 1 and 2 for the left and right-hand channels and 4 the common negative. 3 is the mono positive. Use 3 and 4 for mono cartridges and pre-amplifiers having a separate mono input socket. Also the mono tap of certain stereo cartridges, e.g. Decca ffss. **DO NOT USE 3 AS A SECOND STEREO NEGATIVE** or in the case of the Decca the stereo output will be shorted out.

The foregoing instructions assume that the arm socket will be used in its standard position, fig. 3. It must be remembered that

when re-positioned for non-standard horizontal 2-pin or diagonal 3 and 4-pin plugs the relationship of the connections will be different. Thus, a 2-pin mono head (Ortofon type 'C', for instance) will engage contacts 3 and 2 and a 3-pin stereo head 3 and 2 for the two channels and 4 the common negative. This must be considered when making connections to the output plug. To permit this flexibility of use the screen connection has been kept separate. It is essential to connect the earth tag to the screen of the amplifier connecting lead and to earth. Failure to do this will result in severe hum, especially when the arm is handled. The motor of the turntable unit must also be earthed.



FIG. 3

Arm socket positioned for standard 4-pin plug with horizontal pin arrangement.



FIG. 4

Arm socket re-positioned for non-standard horizontal 2-pin or diagonal 3 and 4-pin plugs by rotating through 45° (see fitting the shell, paragraph 2)

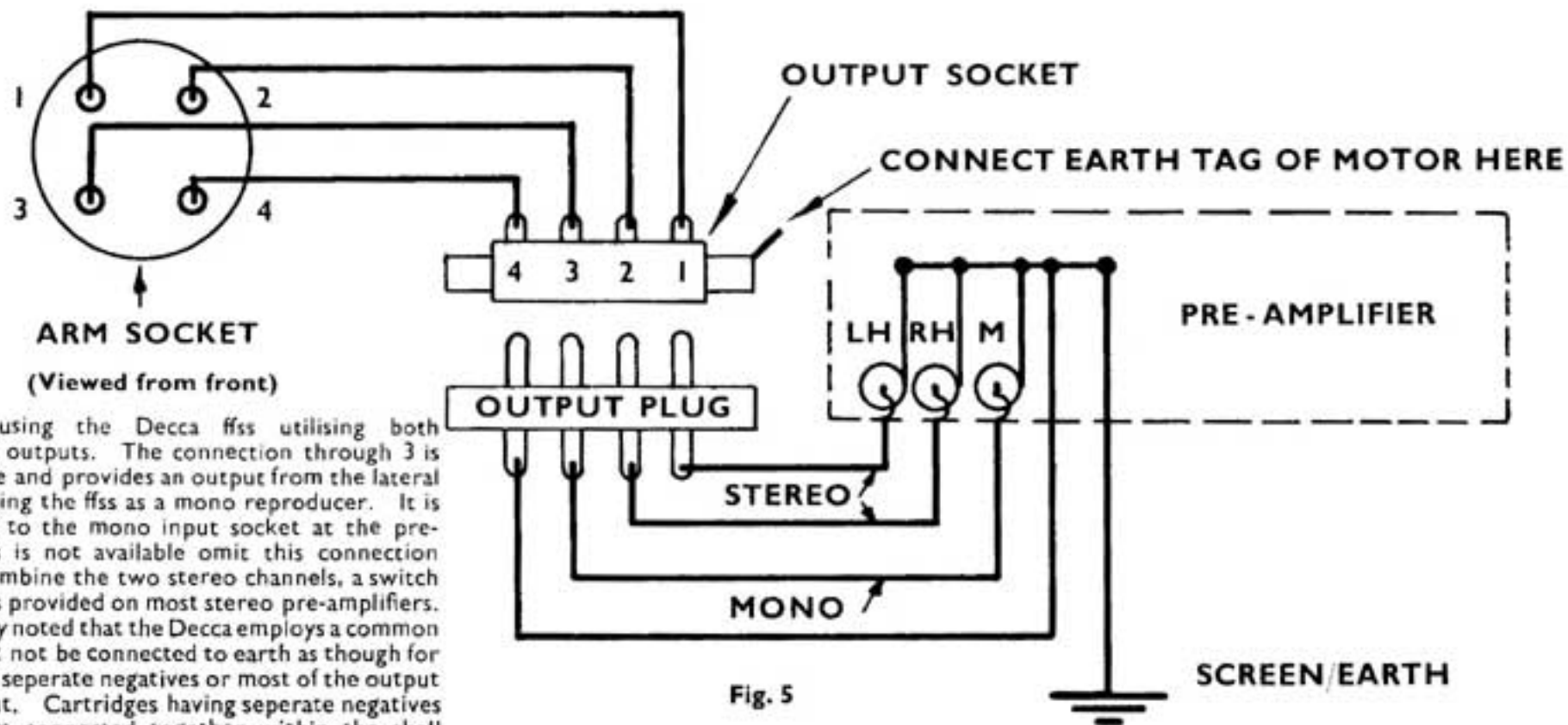

Fig. 5

Typical circuit using the Decca ffss utilising both stereo and mono outputs. The connection through 3 is the mono positive and provides an output from the lateral coil only when using the ffss as a mono reproducer. It is shown connected to the mono input socket at the pre-amplifier. If this is not available omit this connection altogether and combine the two stereo channels, a switch for this purpose is provided on most stereo pre-amplifiers. It must be carefully noted that the Decca employs a common negative. 3 must not be connected to earth as though for a cartridge having separate negatives or most of the output will be shorted out. Cartridges having separate negatives should have them connected together within the shell to pin 4.

FITTING THE SHELL

Remove the rubber band holding the arm in its rest. Take care not to allow the balance weight to swing the arm up violently. Insert the shell plug in the arm socket so that the locating pin enters the slot. Press inwards with one hand and simultaneously screw up the nut with the other. The screw thread will engage the locating pin and draw the plug home. **DO NOT OVER TIGHTEN.**

Finally, check that the bottom of the shell is in a plane parallel to the turntable. If not, shell and nut should be grasped firmly and gently twisted **WHILST HOLDING THE KNIFE EDGE BEARINGS FIRMLY IN ENGAGEMENT.** The socket is a friction fit in the arm and allows this adjustment.

USE WITHOUT SHELL

Certain heads, Ortofon, E.S.L., Neumann, etc., can be plugged directly into the arm socket in place of the S.M.E. shell.

An adaptor, type D.2 allows direct mounting and interchange of Decca heads.

BALANCING

The S.M.E. arms incorporate a unique system which permits both longitudinal and lateral balancing. Having fitted the shell complete with cartridge, proceed as follows:

LONGITUDINAL BALANCE

Move the rider weight as far back as it will go, towards the crank in the way rod, and then forward until its front end coincides with the first graduation mark. Next move the balance weight until the arm assumes a level position. The knife-edge bearings offer very little friction so adjustment is critical.

Finally lock the weight with the set screw "E" which must not be screwed home with the weight removed or the insert which prevents marking of the tone arm extension will be forced out.

LATERAL BALANCE

Place a support under the straight portion of the arm as shown in fig. 6. Slacken set screw "C." Using a screwdriver or similar rod, lift the arm from a point behind the bearings. Adjust the distance between the way rod and the arm by sliding laterally until both knife-edges leave their bearings simultaneously and remain level as the arm is lifted. If extreme accuracy is desired a further check is possible by unscrewing the bed plate from the motor board. Tipping the unit out of level will not cause the arm to swing when it is perfectly balanced. Adjustment to this degree is somewhat critical and must be made a little at a time. Finally, re-tighten the set screw "C".

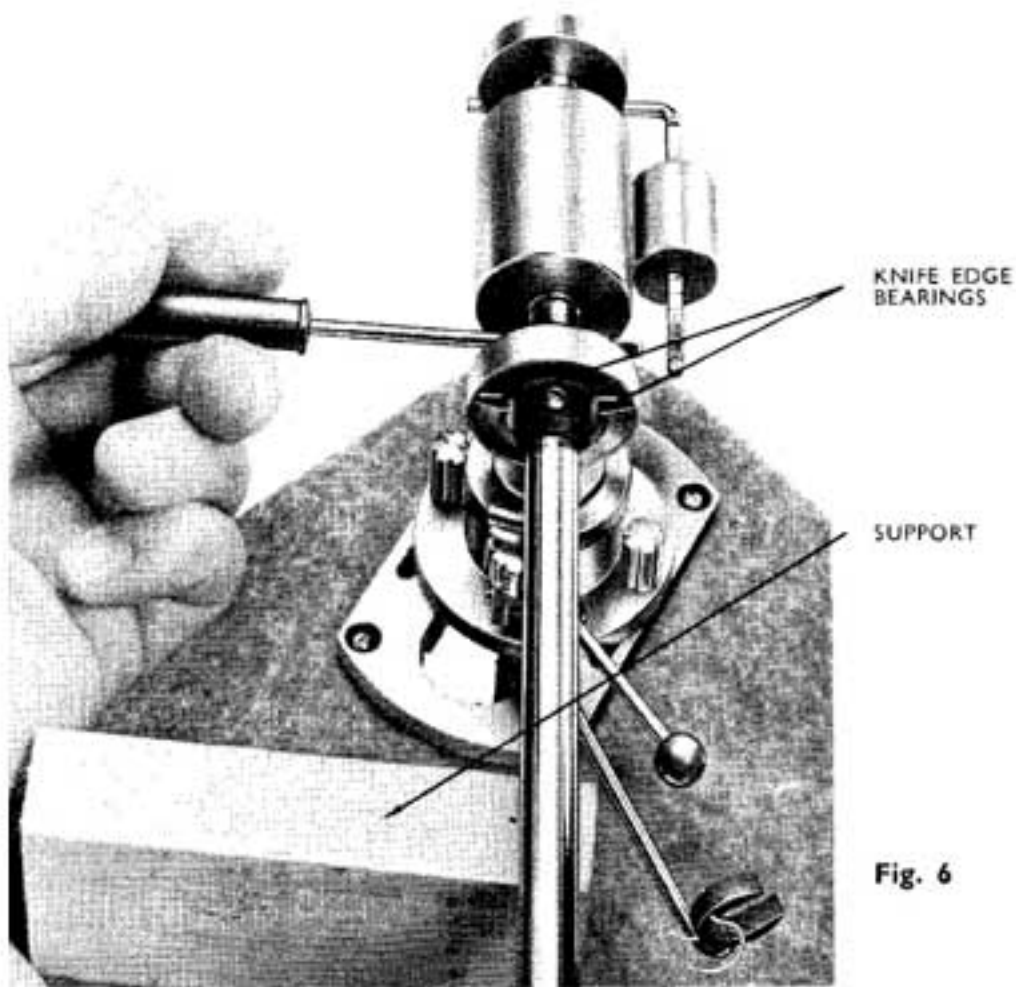

STYLUS PRESSURE

This is applied by moving the rider weight forward along the way rod, each division represents $\frac{1}{2}$ gramme at the stylus. Always start with the front of the weight coinciding with the first graduation mark on the way rod and the arm balanced horizontally. From this condition the pressure applied at the stylus by forward movement of the rider weight is constant irrespective of the cartridge fitted and no pressure gauge is therefore needed. Re-check the longitudinal balance from time to time.

ARM HEIGHT

The main pillar is next adjusted so that when the stylus rests on the record the arm is parallel with the surface of the record. Set screw 'A' can now be finally tightened BUT NO MORE THAN IS NECESSARY TO HOLD THE PILLAR.

ARM CONTROL

This special feature of the S.M.E. precision arm permits feather light lowering and raising of stylus anywhere on a record. If the foregoing instructions have been carried out correctly, movement of control lever to the vertical position will raise the stylus well clear of the record. To operate, start the turntable and sight the stylus

Fig. 6

over the record using the white line on the front of the shell. Move the lever, allowing it to drop down. The stylus will now descend slowly on to the record. With a little practice considerable accuracy of selection is possible. Finally, check that when a record is being played there is clearance between the track of the arm control and the rubber grommet on the underside of the arm. The thickness of a piece of stout paper is a safe minimum. Insufficient clearance is corrected by lowering the pillar slightly, not by attempting to lower the bracket on the pillar. **DO NOT INTERFERE WITH THE SET SCREW 'D'**.

TRACKING

S.M.E. arms should be set to give zero error at $2\frac{1}{4}$ in. radius. An alignment protractor for this purpose is included. Place the perforation over the record spindle and lower the stylus into the pinhole in the protractor. Release the base clamping nuts (Fig. 1) and move the base on it sideways until the printed lines on the protractor are parallel with the centre line of the shell when viewed from above. Relock the nuts. The bed plate has graduations so that

when different cartridges are used, appropriate settings can be noted. Subsequent adjustment is then convenient and rapid.

MOTORS

The performance of even the finest arm and cartridge can be spoilt by an indifferent or worn turntable unit. We cannot stress this too strongly. Often a unit which has given satisfactory service for mono will disclose shortcomings with a stereo pick-up sensitive to vertical vibrations. Use your S.M.E. arm only with a first-class turntable free from wear and mounted in accordance with the maker's instructions. If vibration is present overall reproduction will be affected, sometimes severely.

AMPLIFIER CONNECTIONS

It finally remains to connect the output plug to the amplifier. Use light-weight coaxial or phono lead. Solder appropriate wires to the plug. Thread through the slot in the bottom of the screening can from inside. Insert the plug in its socket and place the can in position over the two spring clips.

CONCLUSION

If the foregoing instructions are faithfully carried out the S.M.E. precision arm will function perfectly.

Strict observation of the following points will ensure continued trouble-free operation:

DO . . .

- ★ Dust arm, and in particular knife-edge bearings, with a small soft brush.
- ★ Handle as befits a high-grade precision instrument.
- ★ Locate main amplifier well away from motor board, at least 6 ft. if possible.
*Mains transformers radiate a strong magnetic field which will spoil the performance of many cartridges.
Loudspeakers cannot reproduce clean bass and hum simultaneously.*

DO NOT in any circumstances . . .

- ★ Unscrew dashpot cover. The special fluid will be lost and can only be obtained from us.
- ★ Alter adjustment of pillar bearings.
- ★ Transport arm without removing balance weights and securing arm in its rest with a rubber band.
- ★ Despatch arm unless packed as supplied in the special carton with all fittings in place.
- ★ Over tighten any of the set screws or interfere with the setting of one marked 'D' which, if over tightened, might distort pillar.
- ★ Allow wiring to become twisted up by rotating base before fitting.
- ★ Apply lubricating oil.

BIAS ADJUSTER

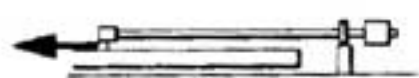
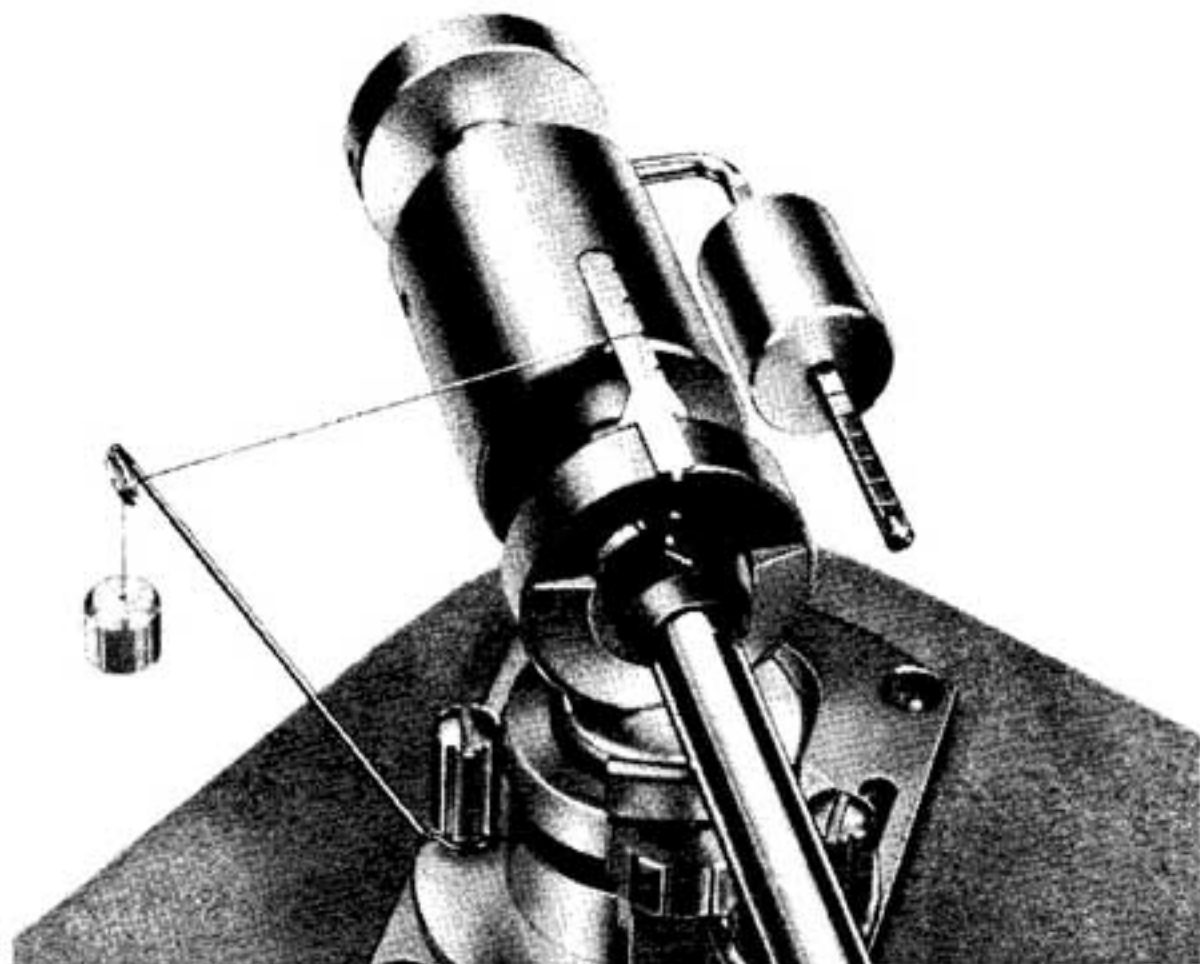

Friction between stylus and groove produces a force which tends to pick-up arm forward. This force is significant with stylus pressure but not significantly with record groove.

Because of the offset of the tone arm the force produces a turning moment about the vertical pivot causing the well known tendency for the arm to swing to the record centre.

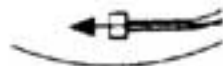

The resulting side pressure is undesirable in stereo causing the tone arm to swing to the one channel and assume an out-of-balance position. Various methods to overcome this have been used, notably springs and counterweights on the tone arm and pick-up arm.

The S.M.E. bias adjuster avoids the use of springs which deteriorate with age and allows the turntable to be used without modification. It embodies a weight acting on a lever attached to the tone arm assembly. The lever is calibrated for a range of weights from 1.5 grammes to 4.5 grammes.

This accessory is fitted in a few minutes to existing tone arms without modification and is supplied complete with stainless steel guide and full instructions for use.

SME

MODELS 3009 & 3012

PRECISION PICK-UP ARMS

INSTRUCTIONS FOR USE

by **S.M.E. LTD** - STEYNING - SUSSEX - ENGLAND - *Phone STEYNING 2228*

Robor Ltd., Haywards Heath, Sussex